



---

# Introduction

- OPRA Turbines is a rapidly growing company which is globally expanding its network and resources to market the OP16's proven technology
- The 1.85 MWe OP16 industrial gas turbine, features an all-radial design, providing robustness, reliability and class leading efficiency
- OPRA's unique combustion technology provides low emissions, dual and bi-fuel and 'off specification' fuel capability
- Complete gas turbine generating sets are engineered to meet customer specific requirements both for land based and offshore applications
- Single or multiple OP16 units can effectively cover installation requirements from 1.5 MW to 10 MW
- The OPRA generator set is well suited for a variety of applications including Oil & Gas and CHP

---

# Application Generator Sets

- **Continuous operation:**
  - Isolated or interconnected operation
  - Parallel operation and synchronization with other units possible
  
- **Peak demands:**
  - Fully automatic starting/stopping
  - Limited voltage dips
  
- **Emergency/standby units :**
  - OP16 can handle load shocks of 100%
  - Hot standby start up time less than 60 seconds

# The 1.85 MWe OP16 Gas Turbine Engine

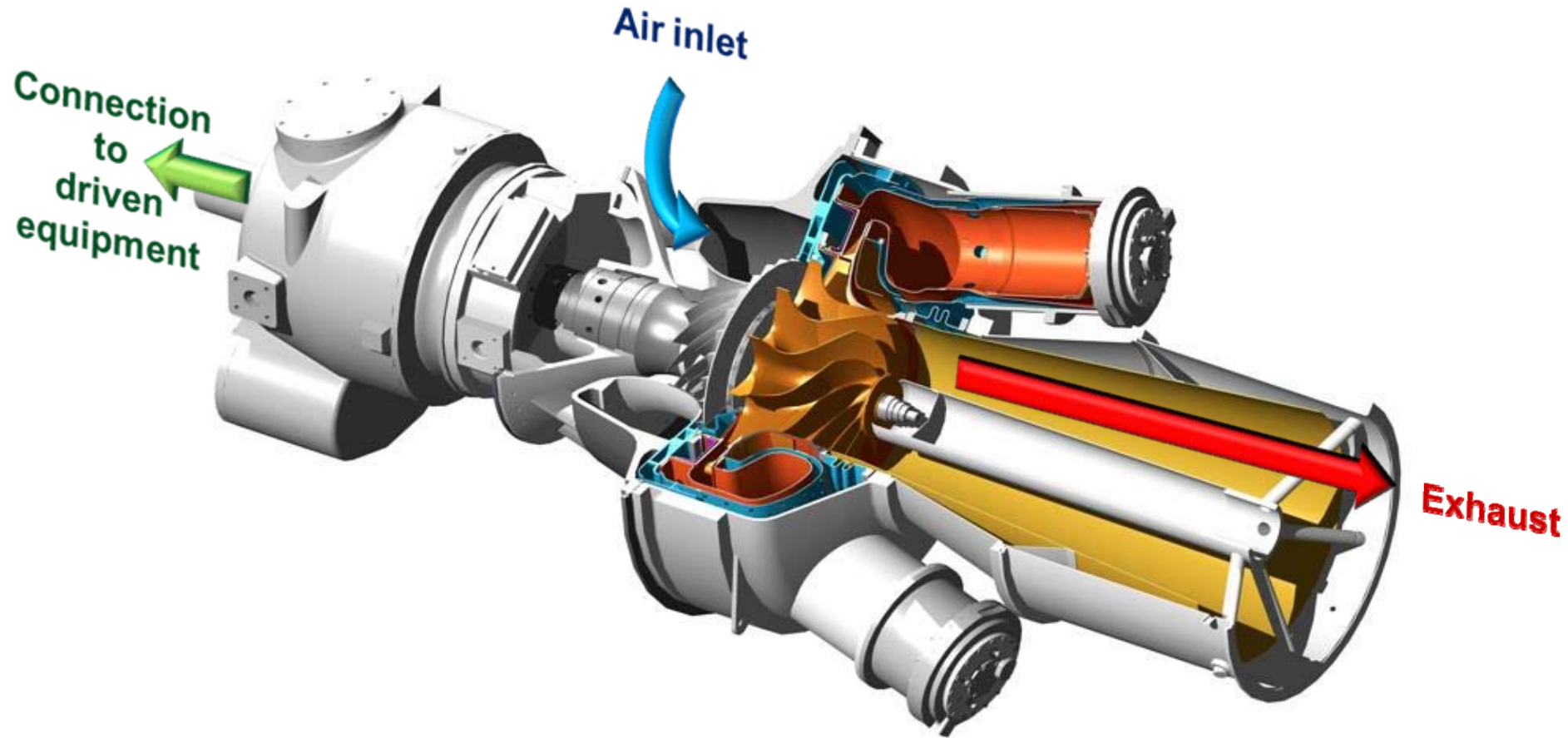

---

# The Simple and Robust All Radial Rotor is the Heart of the OP16 Turbine

- Single stage 6.7:1 compression
- Overhung rotor with bearings in the cold section of turbine
- Hybrid tilting pad / anti-friction bearing system
- Low lube oil flow
- Commercial available industrial type lubricants

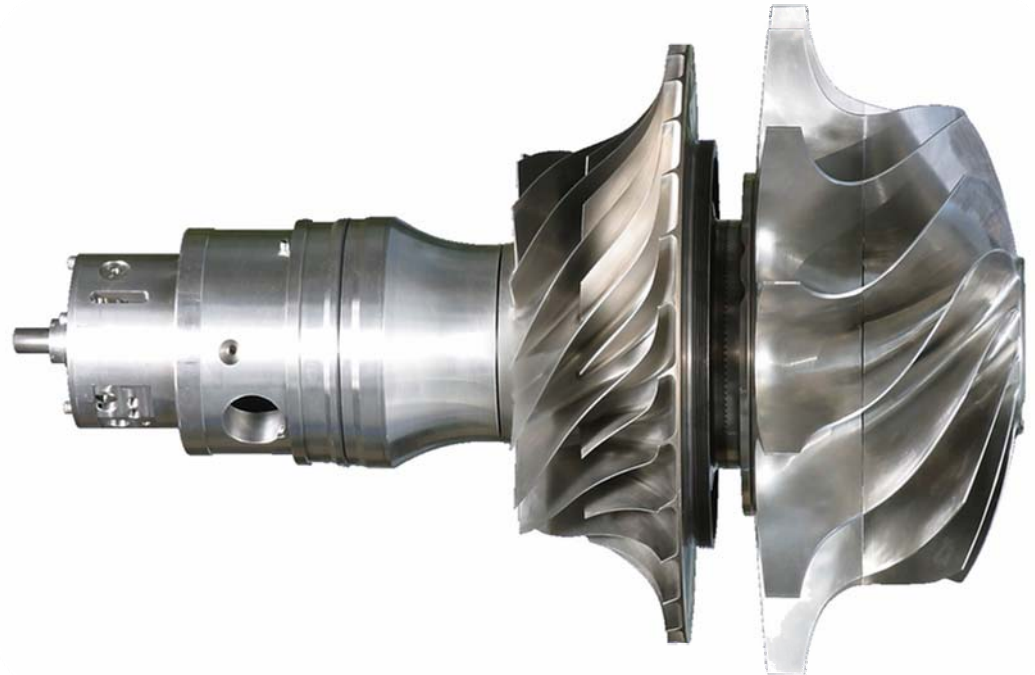

---

# OP16's Advanced Combustion Systems Offer Low Emissions and Dual-Fuel Capabilities

- Four combustor cans for uniform heat distribution
- Maintenance friendly
- Dry low emission combustion system; <25 ppm on natural gas fuel
- Dual fuel – capable to switch under load
- Proven capability of burning a wide range of gaseous and liquid fuels

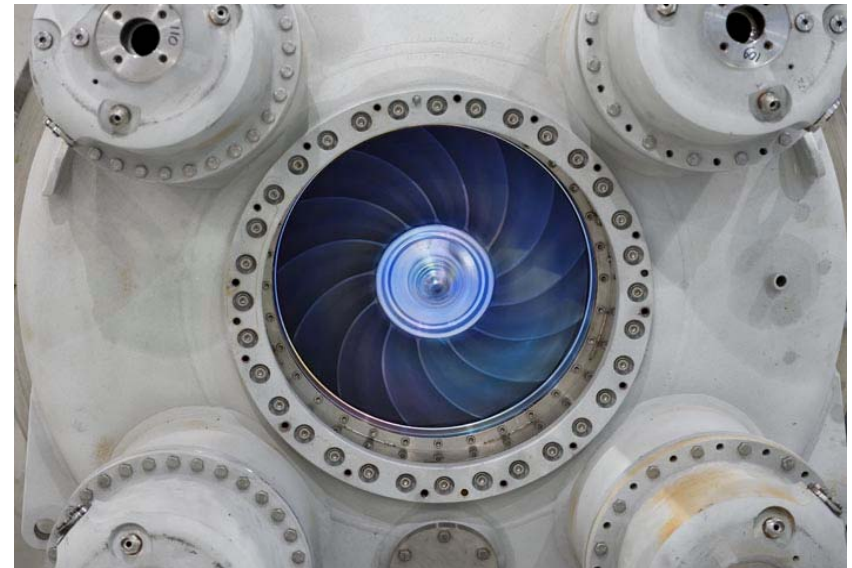

---

# Fuel Flexibility

With its simple and robust design,  
the OP16 operates well on a wide range of fuels:

- Pipeline gas
- Well head gas
- Process associated gas
- Land fill gas
- Biomass fuels
- Diesel fuel
- Kerosene, JP-4



# Package Specifications – Outdoor

## Outdoor package with enclosure and on-base controls

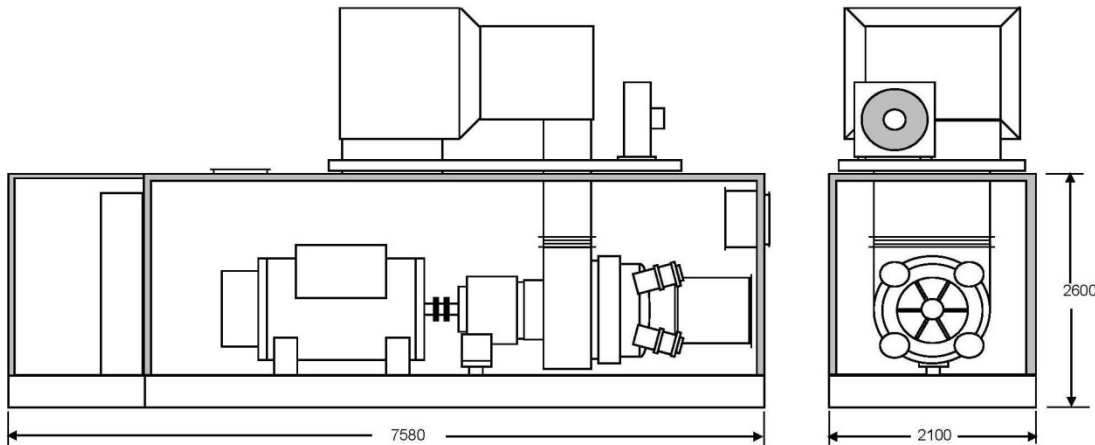

- Includes roof-mounted inlet air filter, inlet air silencing, lube oil cooler and control cabinet installed in integral control room.
- Off-skid control panel is optional.
- Weight, approx. 20,500 kg.

# Maintenance Philosophy

## 3 TYPES OF INSPECTIONS

**A.** 8000 running hr. Inspections (need only 24 hrs downtime)

- ✓ Basic inspection of equipment
- ✓ Replacement of consumable items
- ✓ Calibration of safety critical items

**B.** 16000 running hr. Inspections (need only 24 hrs downtime)

- ✓ 8000 hr. Inspection +
- ✓ Replacement of batteries

**C.** Major Overhauls at 40,000 running hrs (need only 48 hrs downtime)

- ✓ 16000 hr. Inspection +
- ✓ Core engine overhaul and bearing replacement
- ✓ Replacement of life expired components



# Spare Engine Program

- 🌿 Pool of exchange engines available
- 🌿 Guaranteed Availability
- 🌿 Engine ready for shipment within 24 hrs

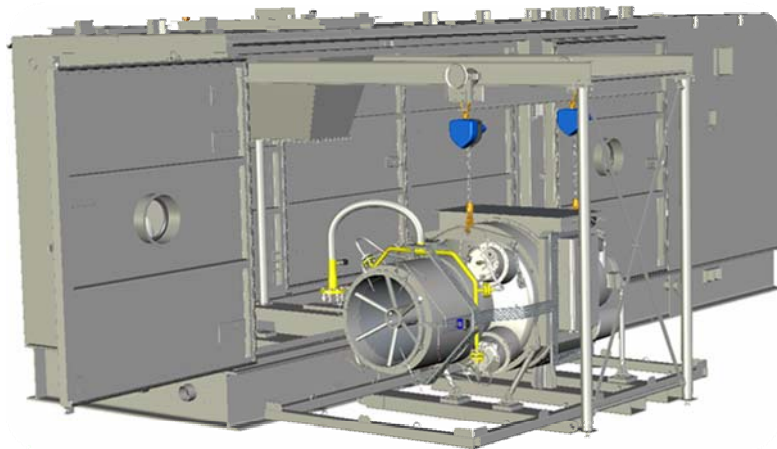

# Technical Comparison

OP16	Recip Engine
<ul style="list-style-type: none"><li>■ Dual/bi fuel system</li><li>■ Seamless switchover</li><li>■ Wide range of fuels</li><li>■ Handles 100% load shocks</li><li>■ Negligible oil consumption</li><li>■ High efficiency</li></ul>	<ul style="list-style-type: none"><li>■ Only one fuel type can be burned</li><li>■ No 100% switchover</li><li>■ Very limited fuel capability</li><li>■ Need load steps</li><li>■ High oil consumption</li><li>■ Higher efficiency</li></ul>

# Heat recovery and heat rejection

## OP16

- High quality exhaust heat
- Small fin-fan lube oil cooler
- No cooling water required
- Hot water/LP steam CHP efficiency up to 92%
- HP steam CHP : >90%
- More suitable for CCHP

## Recip Engine

- Low quality exhaust heat
- Large cooling requirement
- Large c.w. flow required
- Hot water/LP steam CHP efficiency up to 85%
- Not possible
- Less suitable for CCHP

# Installation

## OP16

- Compact
- Low weight (20 tons)
- Simple configuration
- No vibration
- Easy sound attenuation
- 3-4 weeks installation/commissioning

## Recip Engine

- Big and bulky
- High weight (>45 tons)
- Cooling water infrastructure
- Complex foundation issues
- Low frequency noise
- Approx 3 months installation/commissioning

# Service and Maintenance

## OP16

- Balanced rotating assembly
- 8000 hrs without stopping
- MTBO 40,000 hrs (5 years)
- Nominal availability 98-99%

## Recip Engine

- Many moving parts
- Short maintenance intervals (500-1,000 hrs)
- Every 10,000 and 20,000 hrs
- Nominal availability 85-90%

# Competitive Advantages of OP16

- Simple, robust and reliable system
- Low weight and very compact
- Highest efficiency in its class
- Low emissions
- Dual fuel capability
- Wide range of fuels
- Long overhaul intervals
- On skid (pre-wired) controls (option)

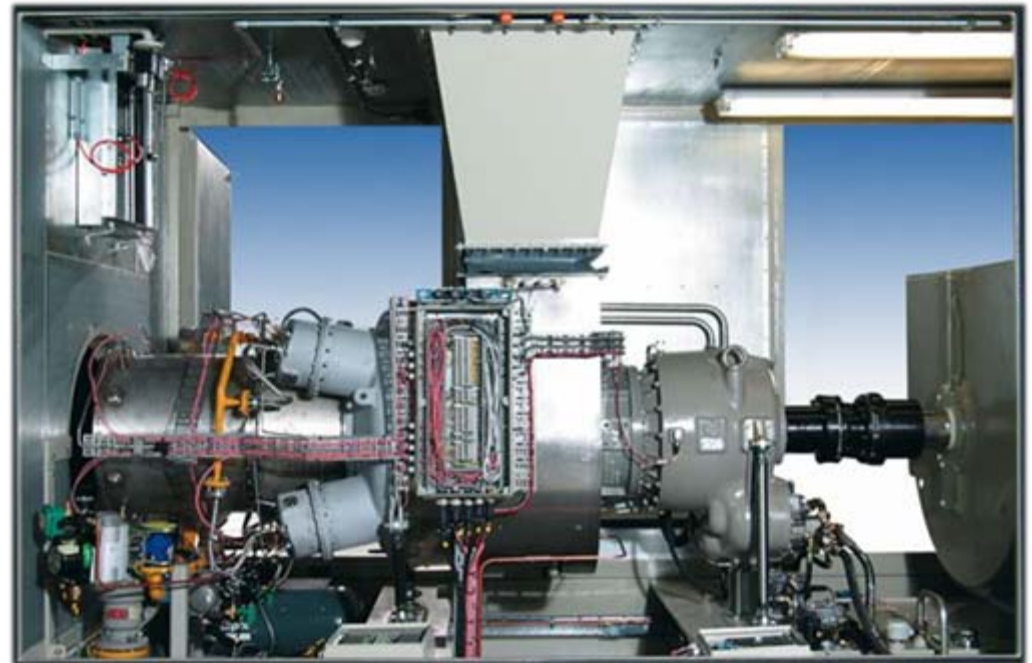

A detailed, high-contrast photograph of a turbine engine's internal components. The image shows several curved, metallic blades arranged in a row, with a central shaft and various mechanical parts. The lighting highlights the metallic textures and the complex geometry of the parts. A green banner is overlaid across the middle of the image.

# The Total Cost of Ownership (TCOO) Concept

---

# Total Cost of Ownership (TCoO)

**“All costs associated with, or directly or indirectly caused by the acquisition and use of materials and services required for the attainment of a specific (total) goal from conception through obsolescence.”**

# The Total Cost of Ownership concept

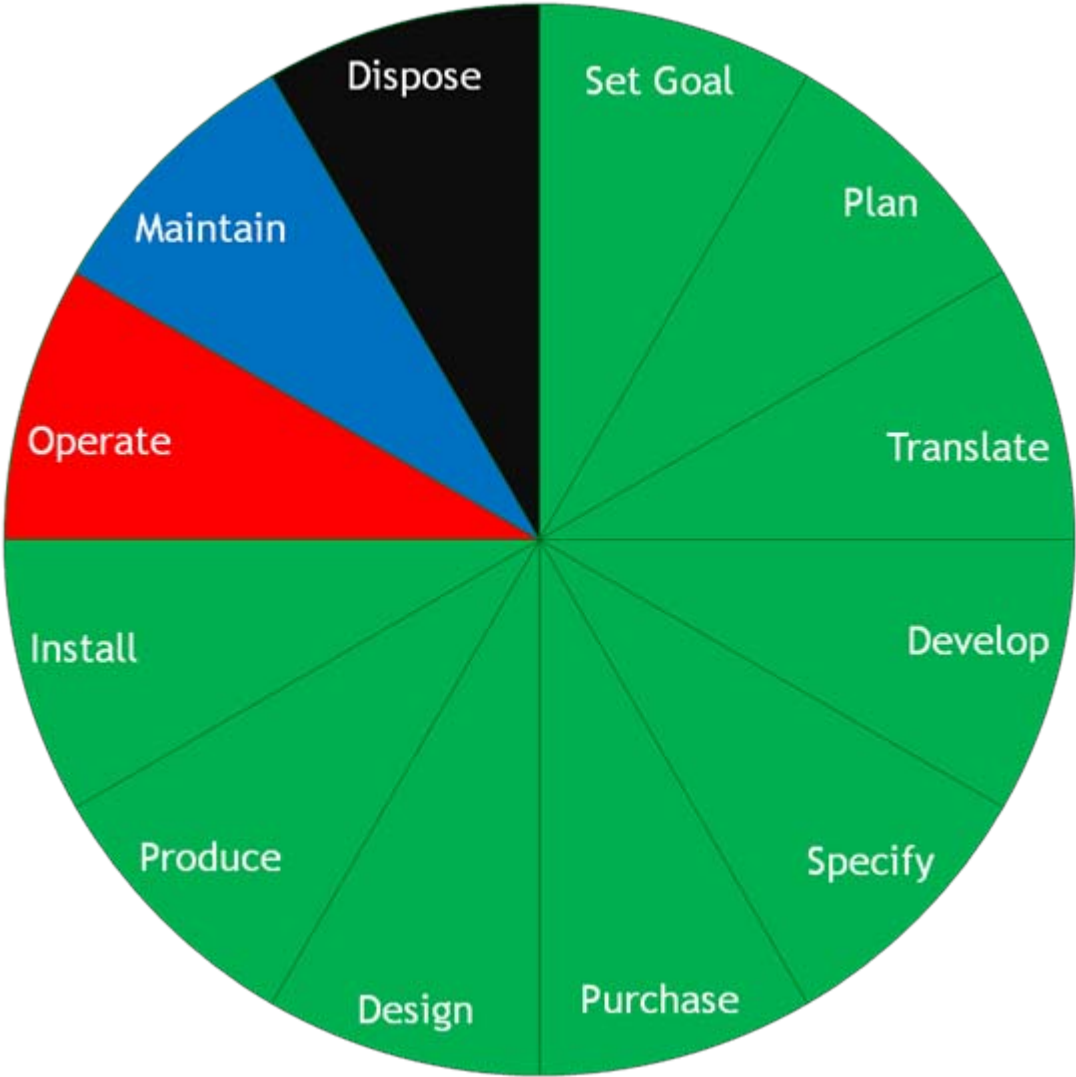

# TCoO Visibility

## "Iceberg Effect"

**Costs usually considered**

**Costs seldom considered**

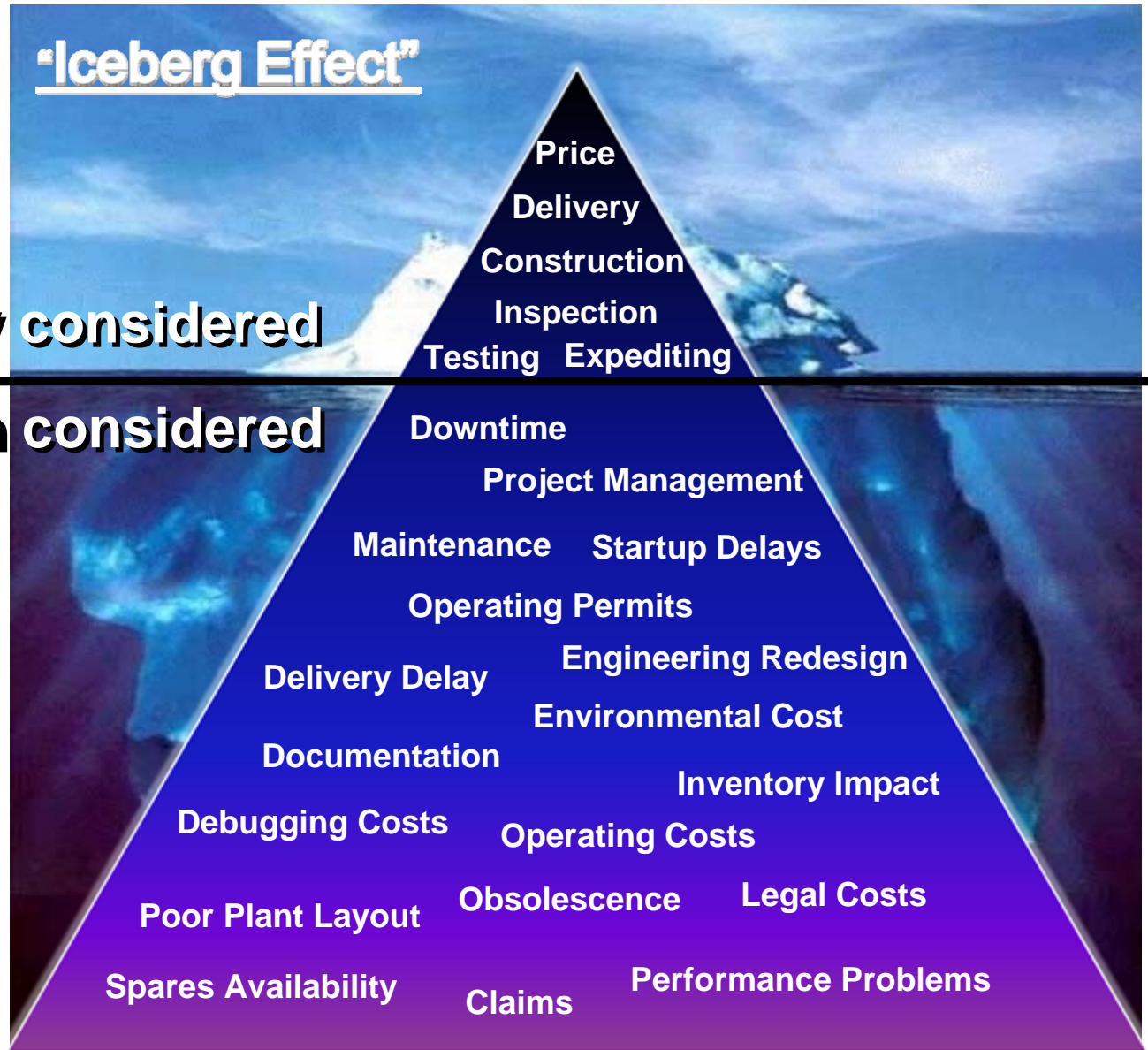

# The Total Cost of Ownership concept

## Cost Factor – “Objectivity Spectrum”

### Hard Data:

- Purchase Cost
- Transportation
- Duties & Taxes

### Approximate Data:

- Energy Cost
- Longevity
- Maintenance Cost
- Production Loss
- Spares Delivery
- Maintenance Rework

### Soft Data:

- Quality
- Reliability
- Environmental Impact
- Supplier Responsiveness

Increasing Objectivity / Certainty

---

# TCoO Categories of Expenditure

**CAPEX = Capital Expenditure**

**OPEX = Operational Expenditure**

**MAINTEX = Maintenance Expenditure**

**DISPEX = Disposal Expenditure**

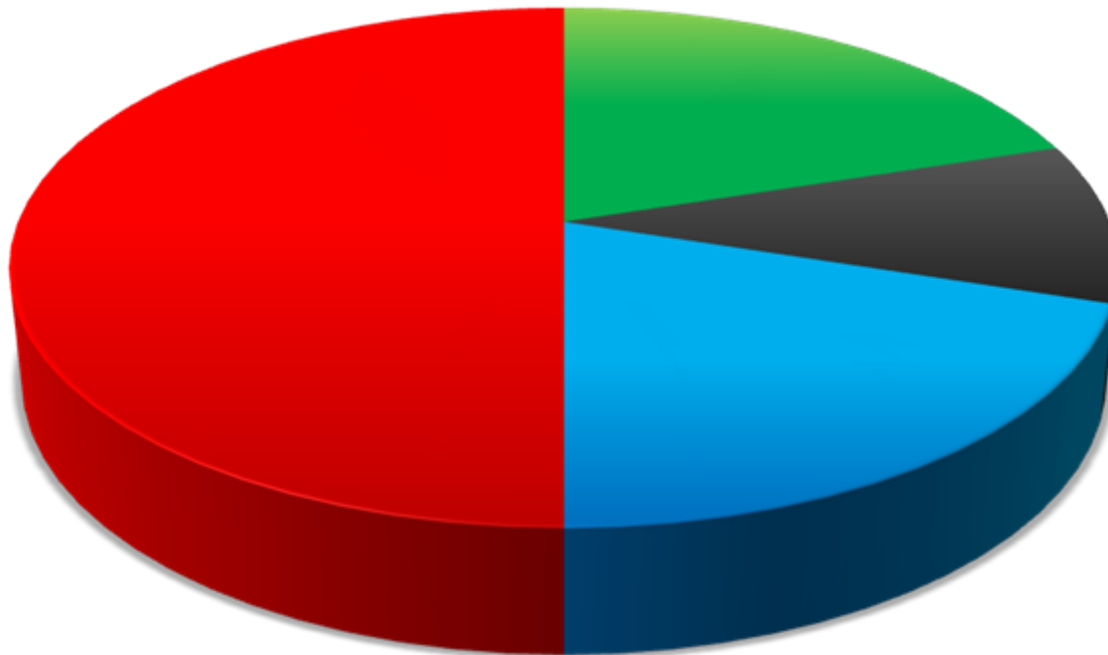

# TCoO Model – Cost Drivers

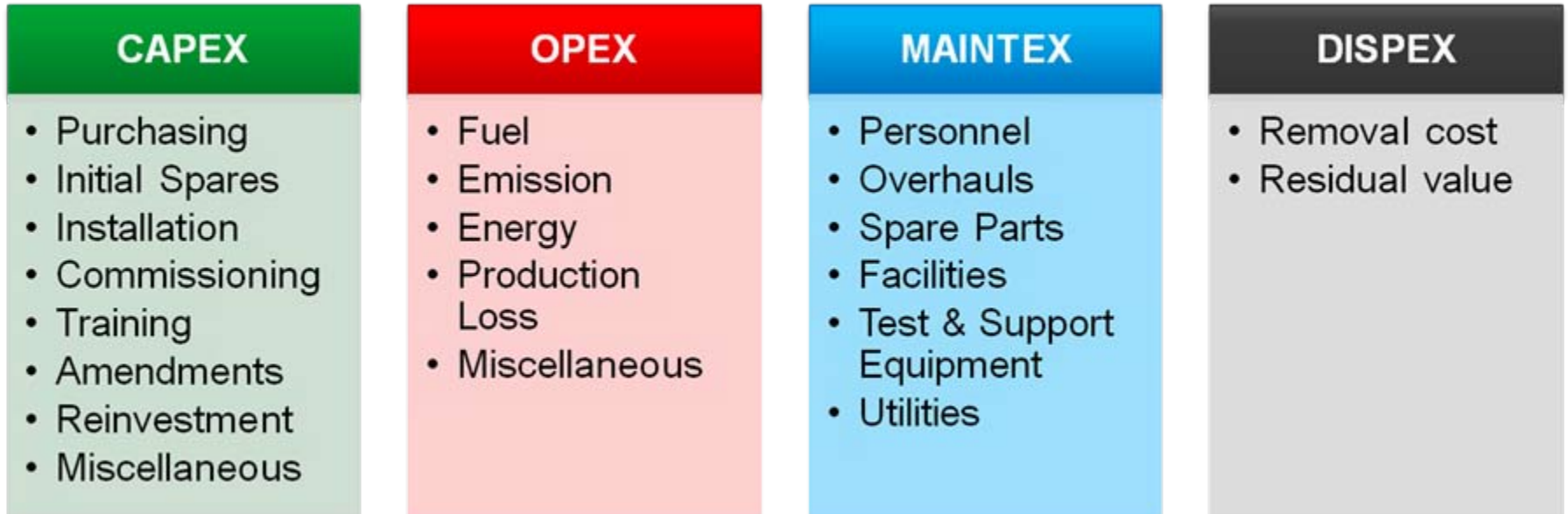

**Total Cost of Ownership**

A detailed, close-up photograph of a gas turbine's internal components. The image shows several large, curved compressor blades arranged in a radial pattern, mounted on a central shaft. The blades have a metallic, polished appearance. The shaft and other internal parts are also visible, showing intricate mechanical details. The background is dark, making the metallic parts stand out.

## Comparison TCoO Gas Turbine and Gas Engine

# Assumptions TCoO Comparison for 20 years

	Gas Turbine	Gas Engine
Site rating	1700 kW	1700 kW
Guaranteed availability	95%*	89%*
Overhauls		No limitation**
Initial investment (incl. spares, excluding installation and commissioning)	€ 1,400,000	€ 900,000
Operations	24/7, onshore oil & gas application, fuel gas € 0,02 per Nm <sup>3</sup> Lube oil € 700/barrel	
Maintenance	Based on full maintenance agreement (incl. scheduled/unscheduled plus overhauls)	
Disposal	Disposal expenditure not taken into account**	

\* = Assumed rate loss of production: € 15,000 per day

\*\* = Usually, a gas engine would be completely replaced after a number of overhauls, this is not taken into account

# Total Cost of Ownership – 20 Years

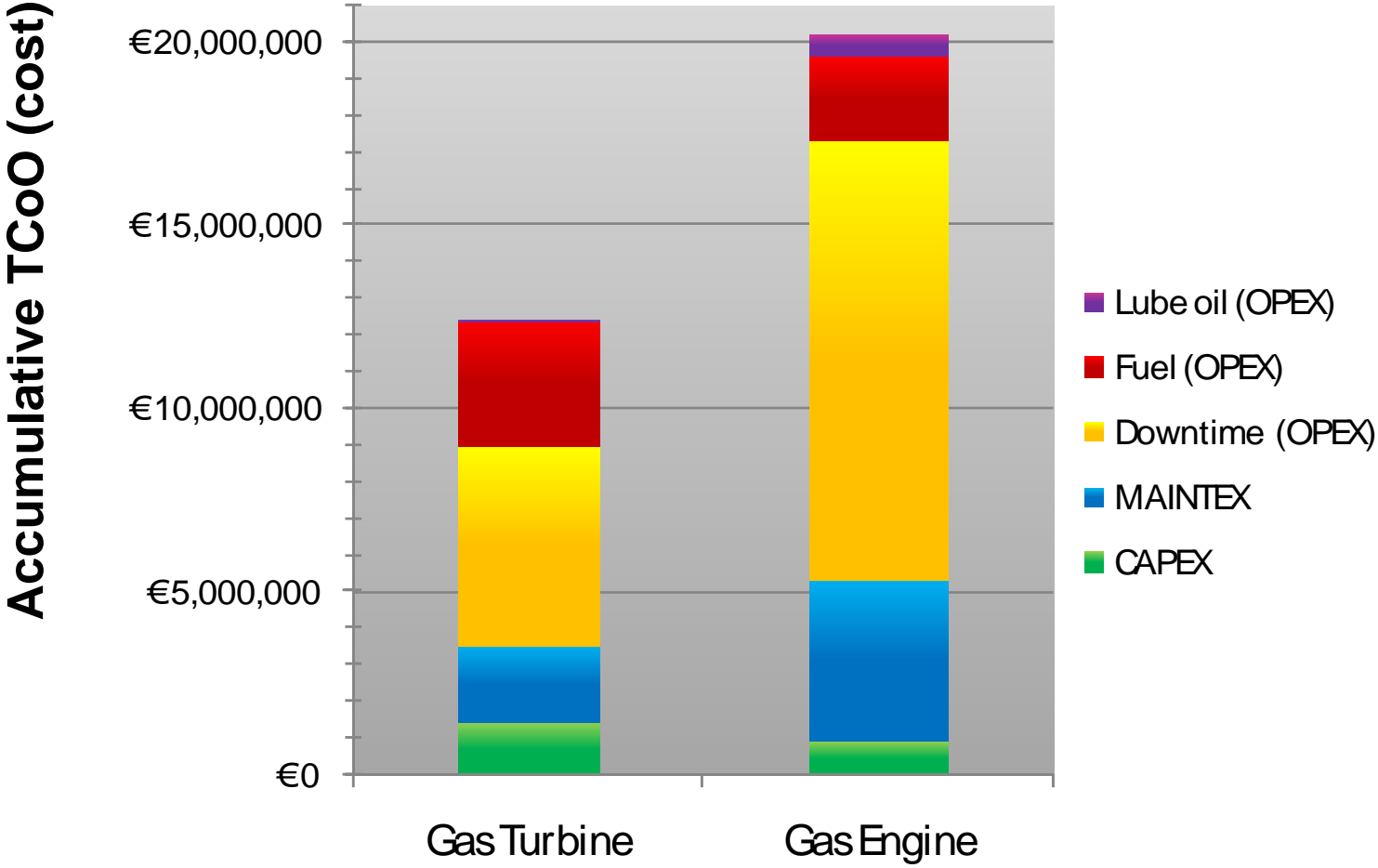

# Payback Time Gas Turbines

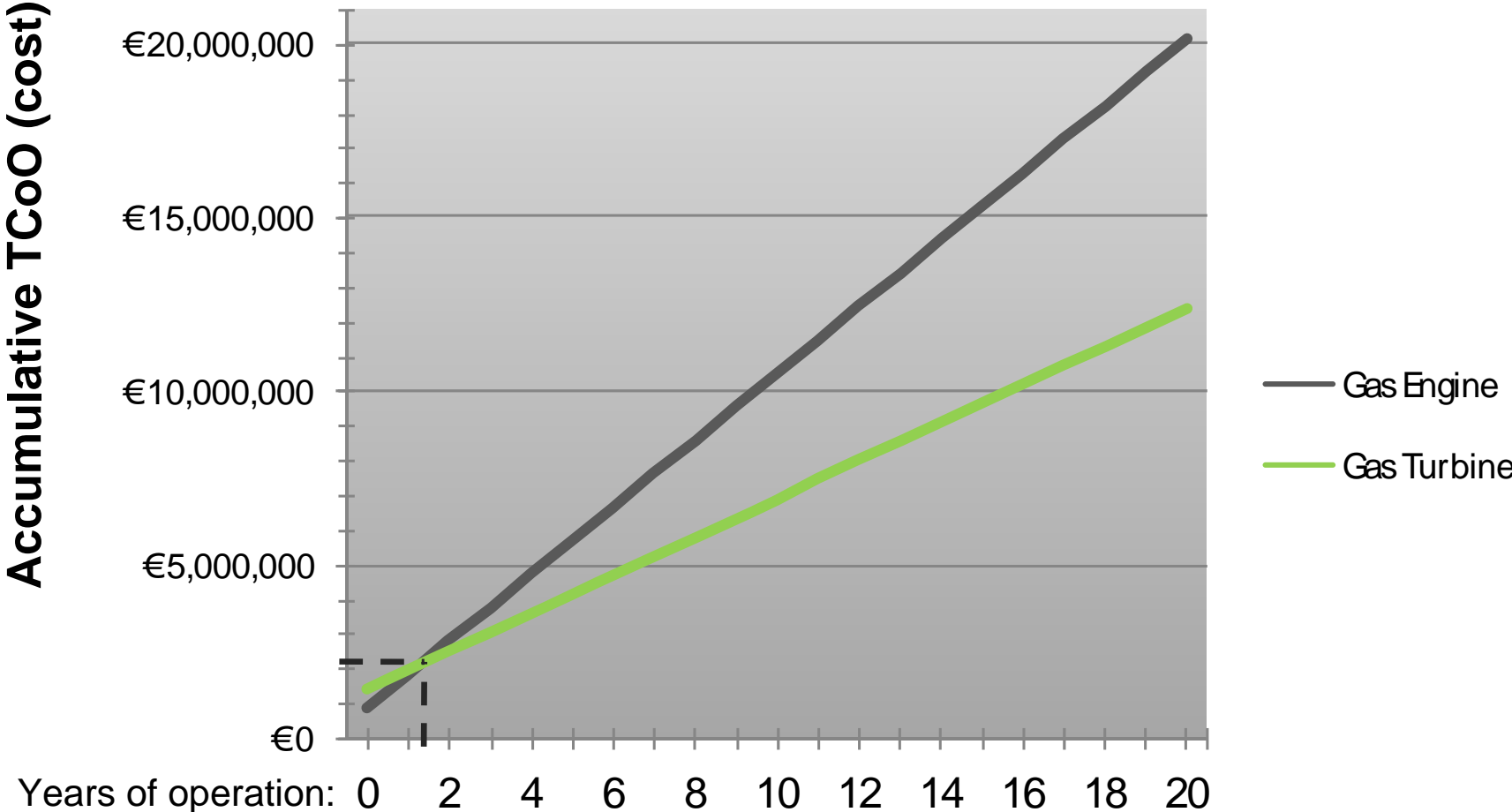

---

# Conclusion

**Despite the higher initial costs, the return on expenditure for gas turbines will be considerably shorter than the payback time of gas engines.**

**This proves that a TCoO calculation should be an important part of the decision making process.**

A detailed close-up photograph of a turbine engine component, showing several curved blades and a central shaft assembly. The blades are metallic and have a polished, reflective surface. The shaft assembly is also metallic and features various components, including a nut and a bolt. The background is dark, making the metallic parts stand out. A green horizontal bar is overlaid across the middle of the image, containing the text "Thank you".

Thank you